



**GENERAL NOTES**

- CAREFULLY UNPACK THE LUMINAIRE AND INSPECT FOR DAMAGE.
- PLEASE WEAR GLOVES TO PROTECT THE FINISH OF THE FIXTURE.
- SAVE THESE INSTRUCTIONS FOR FUTURE REFERENCE.

**NOTICE**

- FOR YOUR SAFETY AND PROPER OPERATION OF LUMINAIRE, READ AND UNDERSTAND ALL INSTRUCTIONS COMPLETELY BEFORE COMMENCING INSTALLATION OF THIS LUMINAIRE.
- THIS LUMINAIRE IS SUITED FOR DAMP LOCATIONS.
- THIS LUMINAIRE IS UL LISTED. WHEN INSTALLING LUMINAIRE, CONFORM TO ALL APPLICABLE LOCAL ELECTRICAL CODES, ORDINANCES, AND THE NATIONAL ELECTRICAL CODE (NEC).
- THIS PRODUCT IS RATED FOR THREE 5W LED PANELS

**CAUTION**

THIS PRODUCT SHOULD BE INSTALLED ONLY BY A LICENSED ELECTRICIAN.

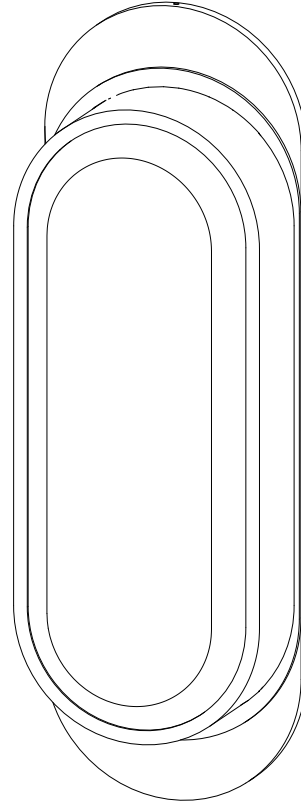

**WARNING**

THE ELECTRICITY MUST BE TURNED OFF AT THE MAIN FUSE BOX BEFORE INSTALLING THIS LUMINAIRE. TURNING POWER OFF USING THE LIGHT SWITCH MAY NOT BE SUFFICIENT TO PREVENT ELECTRICAL SHOCK.

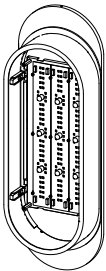
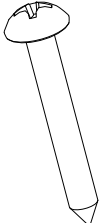
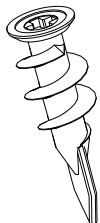

**COMPONENTS PROVIDED FOR INSTALLATION**

**BOX 1**

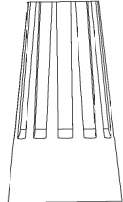
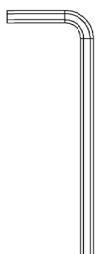
<p><b>FIXTURE BODY</b></p> 	<p><b>MOUNTING SCREWS (X4)</b></p> 	<p><b>WALL ANCHOR (X4)</b></p> 
<p><b>THUMB SCREWS (X4)</b></p> 	<p><b>WIRE NUTS (X2)</b></p> 	<p><b>HEX WRENCH</b></p> 

**BOX 2**

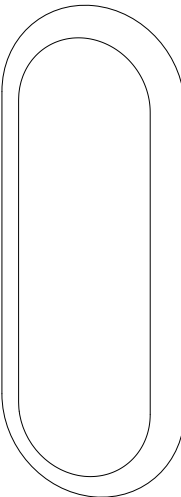
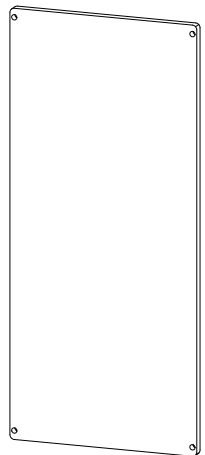
<p><b>GLASS</b></p> 	<p><b>DIFFUSER</b></p> 
--	--



## MOUNTING INSTRUCTIONS - 1 PERSON INSTALL

### STEP 1

SHUT OFF THE MAIN ELECTRICAL SUPPLY TO THE JUNCTION BOX FROM THE FUSE BOX/CIRCUIT BREAKER. TURNING POWER OFF AT THE SWITCH IS NOT SUFFICIENT.

### STEP 2

USING PROVIDED HEX WRENCH, LOOSEN SET SCREWS AT TOP AND BOTTOM OF FIXTURE BODY AND REMOVE MOUNTING PLATE WITH ATTACHED LED PANELS FROM FIXTURE BODY.

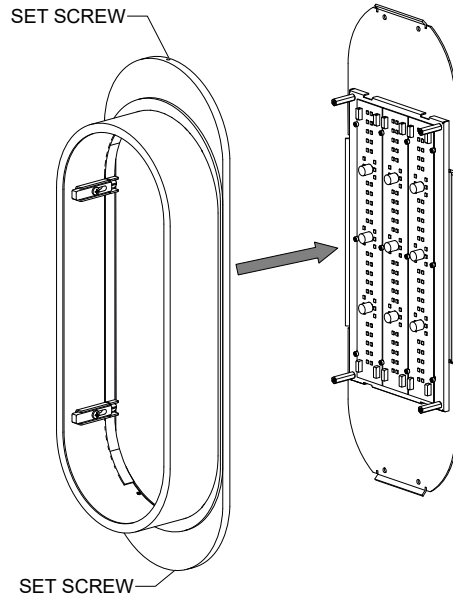

### STEP 3

LOCATE JUNCTION BOX AND INSTALL WALL ANCHORS AT DESIRED LOCATION USING HOLES IN MOUNTING PLATE AS A GUIDE.

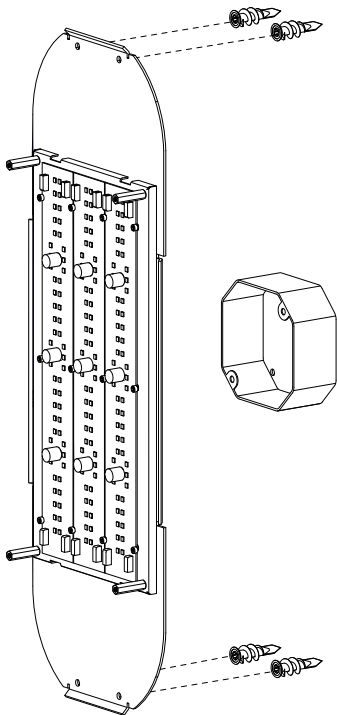

### STEP 4

LIFT ELECTRICAL TO WALL. USING THE WIRE NUTS PROVIDED, MAKE ELECTRICAL CONNECTIONS BY FOLLOWING THE ELECTRICAL CONFIGURATION TABLE BELOW. ENSURE THAT ALL ELECTRICAL CONNECTIONS ARE WRAPPED WITH UL-LISTED ELECTRICAL TAPE.

**IMPORTANT: NEVER ALLOW FIXTURE TO "HANG" FROM ELECTRICAL CONNECTIONS OR TO OTHERWISE PUT PRESSURE ON THE CONNECTIONS. THE WEIGHT OF THE FIXTURE SHOULD BE SUPPORTED BY THE MOUNTING ASSEMBLY.**

ATTACH MOUNTING PLATE TO WALL WITH MOUNTING SCREWS. CHECK LEVEL ON MOUNTING PLATE.

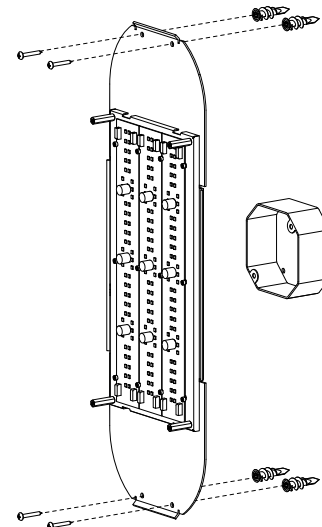



# CAB, WR

## ASSEMBLY AND MOUNTING INSTRUCTIONS

UE-2406WR

### STEP 5

INSTALL DIFFUSER OVER LED PANELS WITH THUMB SCREWS.

RETURN POWER TO CIRCUIT, CONFIRM PROPER OPERATION OF FIXTURE.

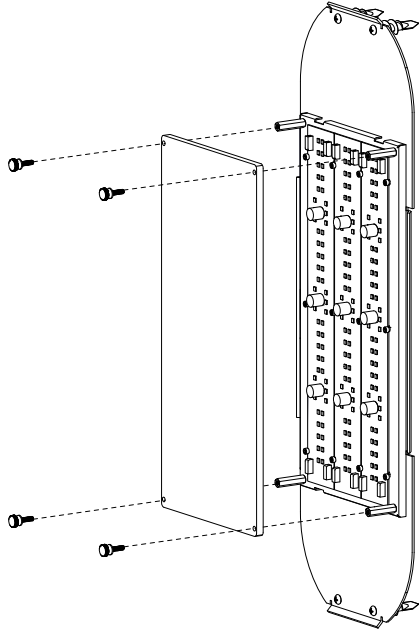

### STEP 6

REMOVE 2 OF THE SLOTTED SCREWS FROM INSIDE OF FIXTURE BODY ON ONE SIDE. REMOVE SLIDERS AND SET ASIDE.

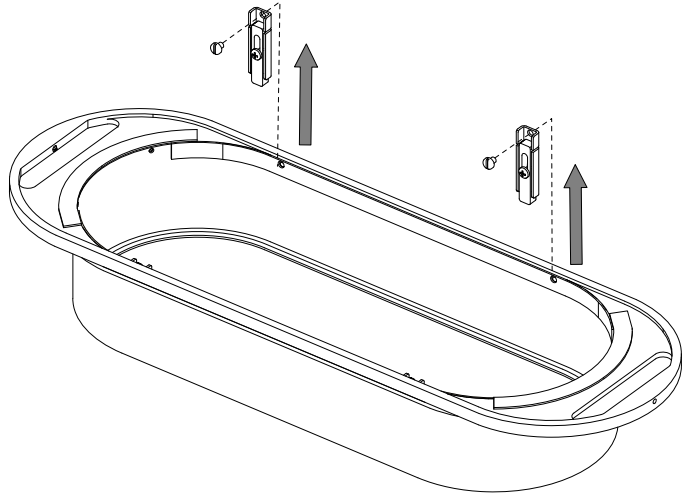

### STEP 7

INSERT GLASS INTO FIXTURE BODY FROM THE BACK.

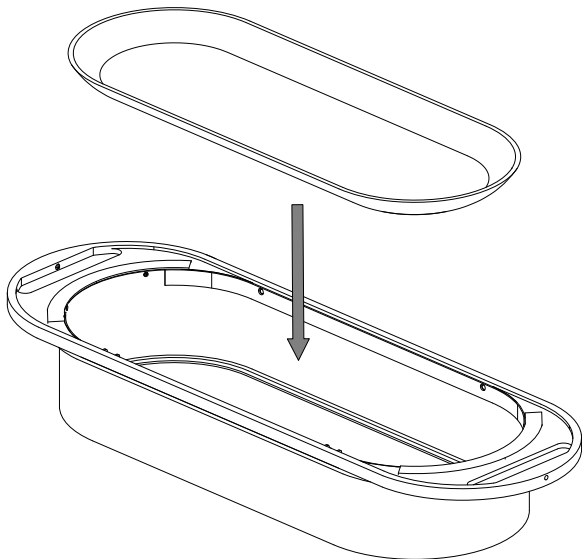

### STEP 8

REATTACH THE TWO SLIDERS WITH SLOTTED SCREWS.

LOOSEN PHILLIPS HEAD SCREWS IN ALL FOUR SLIDERS AND ADJUST NYLON BLOCKS SO THAT BLOCKS ARE SNUG AGAINST GLASS. RETIGHTEN PHILLIPS HEAD SCREWS TO SECURE NYLON BLOCKS IN PLACE.

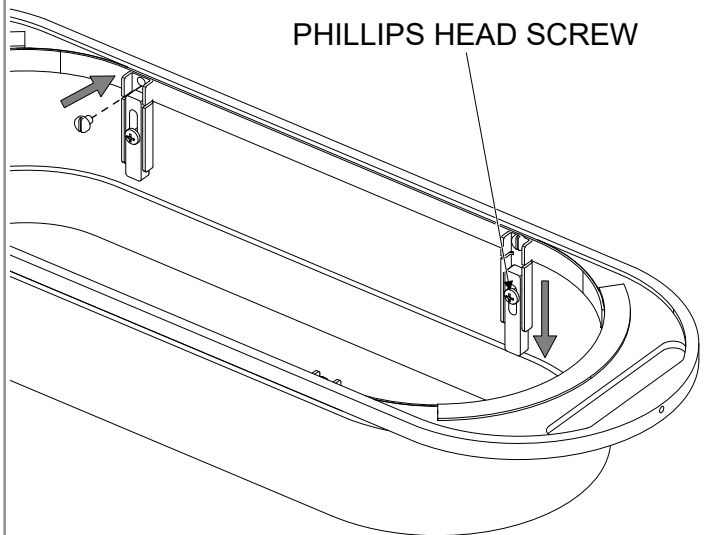



# CAB, WR

## ASSEMBLY AND MOUNTING INSTRUCTIONS

UE-2406WR

### STEP 9

SLIP FIXTURE BODY OVER MOUNTING PLATE AND RETIGHTEN SET SCREWS.

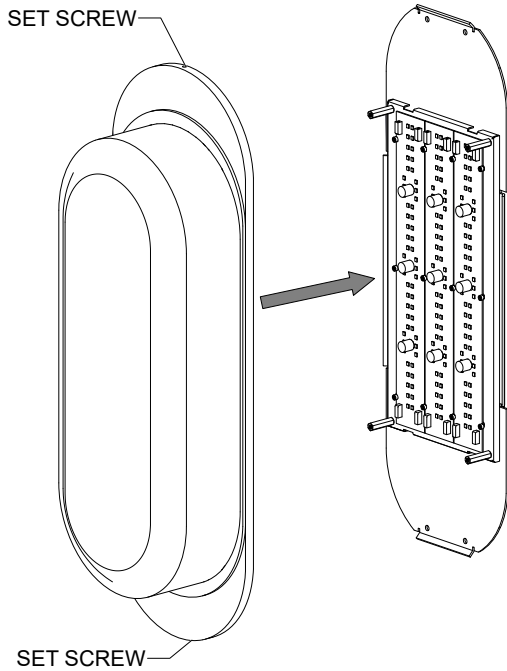

---

## ELECTRICAL CONFIGURATION TABLE

FROM HOME	FROM LUMINAIRE
CONNECT BLACK OR RED (HOT) HOUSE SUPPLY CIRCUIT WIRE TO:	LUMINAIRE ROUND/BLACK WIRE (HOT)
CONNECT WHITE (NEUTRAL) HOUSE SUPPLY CIRCUIT WIRE TO:	LUMINAIRE RIBBED/WHITE WIRE (NEUTRAL)
CONNECT GREEN INSULATED OR BARE COPPER (GROUND -) HOUSE SUPPLY CIRCUIT WIRE AND LUMINAIRE BARE STRANDED WIRE (GROUND -) TO GREEN GROUND SCREW ON CROSSBAR.	

**GENERAL NOTE:** USE UL LISTED WIRE NUTS FOR THE WIRING CONNECTIONS IN THIS LUMINAIRE. WRAP WIRE NUT CONNECTIONS WITH UL LISTED ELECTRICAL TAPE.

FOR QUESTIONS, PLEASE CONTACT CLIENT SERVICES AT: 843.723.8140 OR [INFO@URBANELECTRICCO.COM](mailto:INFO@URBANELECTRICCO.COM)