



AMPHORA, HR

ASSEMBLY AND MOUNTING INSTRUCTIONS

UE-2541HR

GENERAL NOTES

- CAREFULLY UNPACK THE LUMINAIRE AND INSPECT FOR DAMAGE.
- PLEASE WEAR GLOVES TO PROTECT THE FINISH OF THE FIXTURE.
- SAVE THESE INSTRUCTIONS FOR FUTURE REFERENCE.

NOTICE

- FOR YOUR SAFETY AND PROPER OPERATION OF LUMINAIRE, READ AND UNDERSTAND ALL INSTRUCTIONS COMPLETELY BEFORE COMMENCING INSTALLATION OF THIS LUMINAIRE.
- THIS LUMINAIRE IS SUITED FOR DAMP LOCATIONS.
- THIS LUMINAIRE IS UL LISTED. WHEN INSTALLING LUMINAIRE, CONFORM TO ALL APPLICABLE LOCAL ELECTRICAL CODES, ORDINANCES, AND THE NATIONAL ELECTRICAL CODE (NEC).
- THIS PRODUCT IS RATED FOR ONE 60W TYPE A BULB

CAUTION

THIS PRODUCT SHOULD BE INSTALLED ONLY BY A LICENSED ELECTRICIAN.

WARNING

THE ELECTRICITY MUST BE TURNED OFF AT THE MAIN FUSE BOX BEFORE INSTALLING THIS LUMINAIRE. TURNING POWER OFF USING THE LIGHT SWITCH MAY NOT BE SUFFICIENT TO PREVENT ELECTRICAL SHOCK.

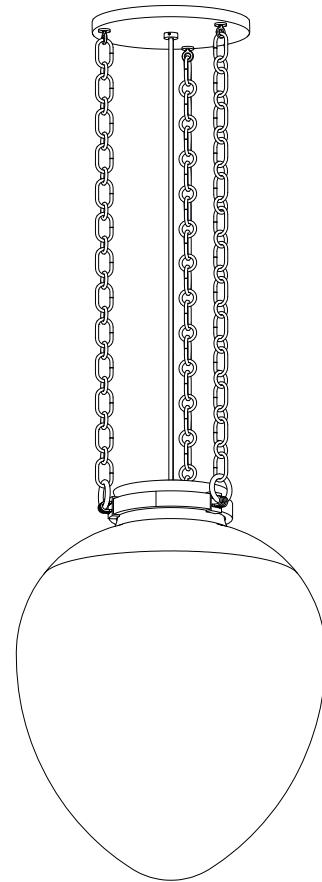

COMPONENTS PROVIDED FOR INSTALLATION

BOX 1

ELECTRICAL	COLLAR	CANOPY	CHAIN (X3)	MOUNTING PLATE	BULB
	TOGGLE BOLTS & WASHERS (X3) 	HEX NUT & LOCK-WASHER 	HEX WRENCH 	WIRE NUTS (X2) 	STEEL SCREW (X2)

BOX 2

COMPONENT



AMPHORA, HR

ASSEMBLY AND MOUNTING INSTRUCTIONS

UE-2541HR

MOUNTING INSTRUCTIONS - 2 PERSON INSTALL

STEP 1

SHUT OFF THE MAIN ELECTRICAL SUPPLY TO THE JUNCTION BOX FROM THE FUSE BOX/CIRCUIT BREAKER. TURNING POWER OFF AT THE SWITCH IS NOT SUFFICIENT.

STEP 2

LOCATE JUNCTION BOX AND USE MOUNTING PLATE TO MARK AND DRILL HOLES FOR TOGGLE BOLTS.

SCREW STEEL SCREWS INTO JUNCTION BOX LEAVING EXTRA THREADS EXPOSED.

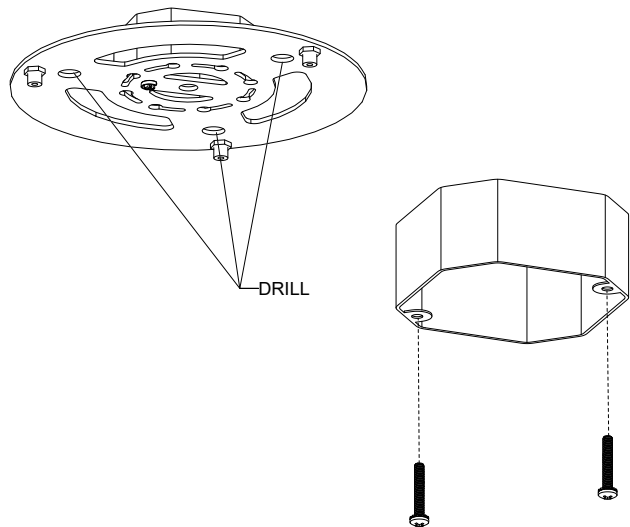

STEP 3

UNSCREW SCREW COLLAR FROM STRAIN RELIEF NIP AND SLIDE DOWN LENGTH OF ELECTRICAL WIRING.

SLIP CANOPY DOWN WIRING AND ALLOW TO REST ON SCREW COLLAR.

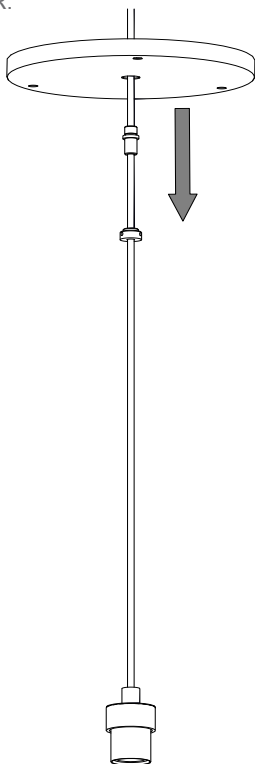

STEP 4

SLIP MOUNTING PLATE OVER STRAIN RELIEF NIP AND SECURE WITH LOCK WASHER AND HEX NUT.

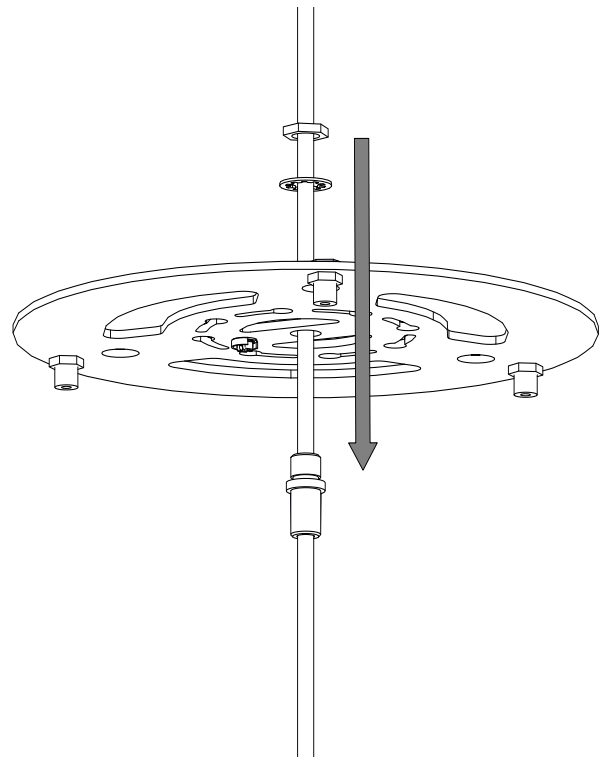



AMPHORA, HR

ASSEMBLY AND MOUNTING INSTRUCTIONS

UE-2541HR

STEP 5

LIFT MOUNTING PLATE TO CEILING AND SLIP STEEL SCREW HEADS THROUGH SLOTTED HOLES IN MOUNTING PLATE. ROTATE PLATE SO THAT MOUNTING PLATE RESTS ON SCREW HEADS WHILE YOU MAKE WIRE CONNECTIONS.

PULL HOUSE SUPPLY WIRES THOROUGH SIDE HOLE IN MOUNTING PLATE.

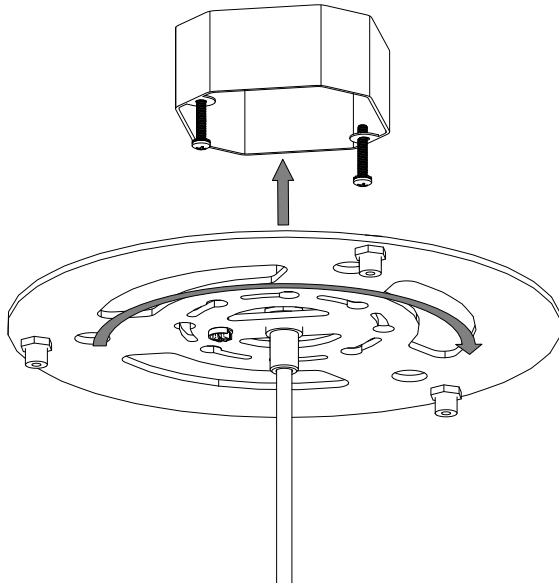

STEP 6

USING THE WIRE NUTS PROVIDED, MAKE ELECTRICAL CONNECTIONS BY FOLLOWING THE ELECTRICAL CONFIGURATION TABLE BELOW. ENSURE THAT ALL ELECTRICAL CONNECTIONS ARE WRAPPED WITH UL-LISTED ELECTRICAL TAPE.

IMPORTANT: NEVER ALLOW FIXTURE TO "HANG" FROM ELECTRICAL CONNECTIONS OR TO OTHERWISE PUT PRESSURE ON THE CONNECTIONS. THE WEIGHT OF THE FIXTURE SHOULD BE SUPPORTED BY THE MOUNTING ASSEMBLY.

STEP 7

INSTALL TOGGLE BOLTS WITH WASHERS.

TIGHTEN STEEL SCREWS SO THAT MOUNTING PLATE IS SNUG TO CEILING.

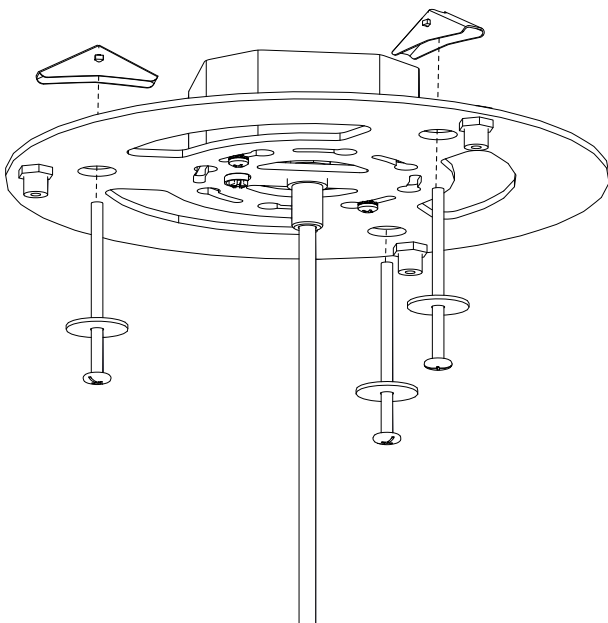

STEP 8

LIFT CANOPY TO CEILING AND SECURE WITH SCREW COLLAR. TAKE CARE TO ALIGN THREE HOLES IN CANOPY WITH HEX NIP THREADS OF MOUNTING PLATE. TIGHTEN SET SCREWS IN SCREW COLLAR WITH HEX WRENCH.

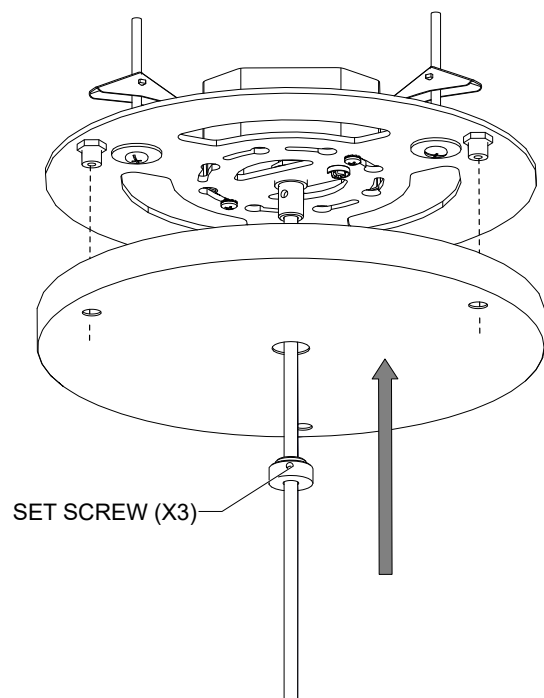



AMPHORA, HR

ASSEMBLY AND MOUNTING INSTRUCTIONS

UE-2541HR

STEP 9

INSTALL BULB, RETURN POWER TO CIRCUIT. CONFIRM PROPER OPERATION OF FIXTURE.

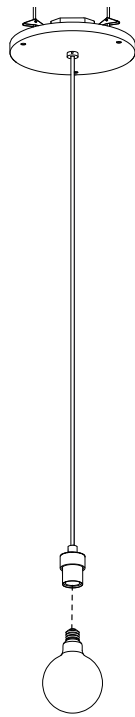

STEP 10

SCREW THREADED EYE BOLTS THROUGH HOLES IN CANOPY, INTO HEX NIPS IN MOUNTING PLATE.

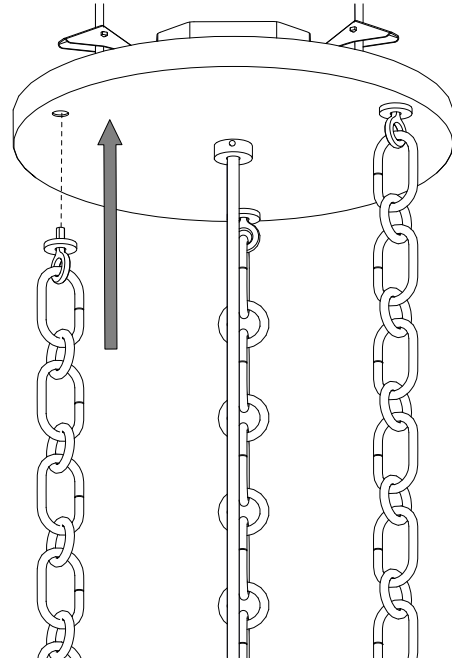

STEP 11

USING HEX WRENCH, UNSCREW ONE SET SCREW FROM COLLAR AND CAREFULLY OPEN ASSEMBLY JUST ENOUGH FOR COLLAR TO FIT OVER NECK OF GLASS GLOBE.

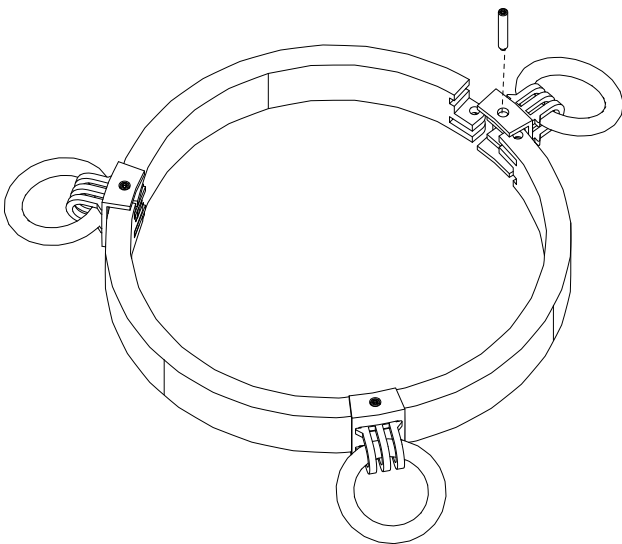

STEP 12

LEAVE GLASS STANDING STRAIGHT UP IN BOX FOR SUPPORT AND CAREFULLY SLIP COLLAR AROUND NECK OF GLASS, REASSEMBLE COLLAR COMPONENTS AND SECURE WITH SET SCREW.

DO NOT OVERTIGHTEN SET SCREW.

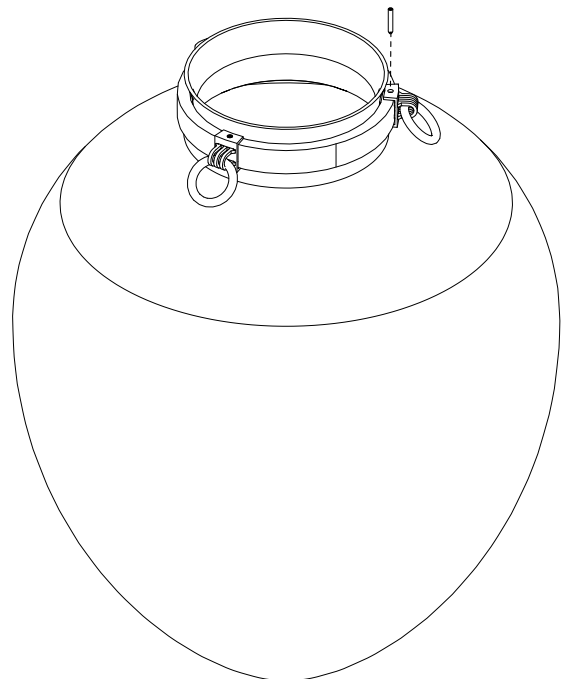



AMPHORA, HR

ASSEMBLY AND MOUNTING INSTRUCTIONS

UE-2541HR

STEP 13

LIFT GLASS OVER ELECTRICAL ASSEMBLY.

CONNECT CHAINS TO LOOPS ON COLLAR BY OPENING A LINK AT END OF EACH CHAIN.

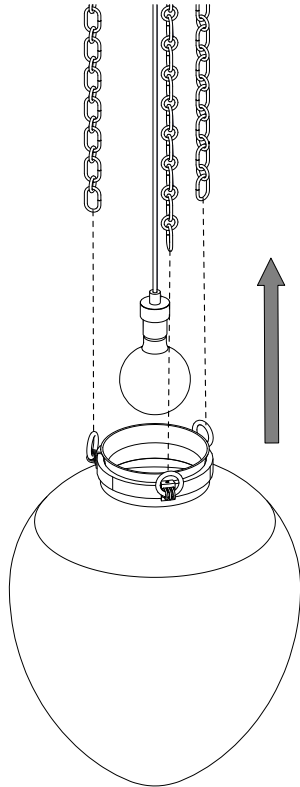

ELECTRICAL CONFIGURATION TABLE

FROM HOME	FROM LUMINAIRE
CONNECT BLACK OR RED (HOT) HOUSE SUPPLY CIRCUIT WIRE TO:	LUMINAIRE ROUND/BLACK WIRE (HOT)
CONNECT WHITE (NEUTRAL) HOUSE SUPPLY CIRCUIT WIRE TO:	LUMINAIRE RIBBED/WHITE WIRE (NEUTRAL)
CONNECT GREEN INSULATED OR BARE COPPER (GROUND -) HOUSE SUPPLY CIRCUIT WIRE AND LUMINAIRE BARE STRANDED WIRE (GROUND -) TO GREEN GROUND SCREW ON CROSSBAR.	

GENERAL NOTE: USE UL LISTED WIRE NUTS FOR THE WIRING CONNECTIONS IN THIS LUMINAIRE. WRAP WIRE NUT CONNECTIONS WITH UL LISTED ELECTRICAL TAPE.

FOR QUESTIONS, PLEASE CONTACT CLIENT SERVICES AT: 843.723.8140 OR INFO@URBANELECTRICCO.COM